

# eclipse



## EXCITEMENT OF SIGHT

Stainless steel meets with elegance in the attractive lines of this radiator. Enjoy the sight of Eclipse.



technical specs page 107

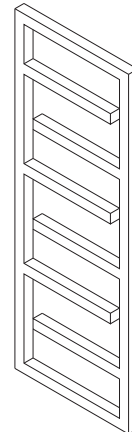
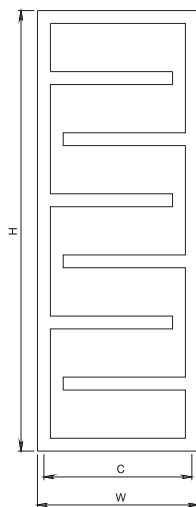
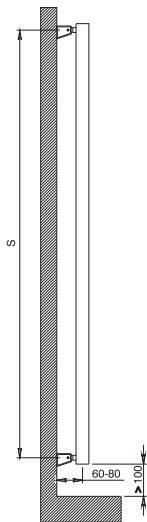
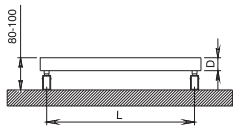

**eclipse**

material	finish	electric version	wall installation	warranty
stainless steel	satin polished	600 W 900 W	vertical	10 years

max. working pressure: 10 bar  
 max. working temperature: 95°C  
 all dimensions are in mm.  
 connections 1/2"

Product Code	Width	Height	Depth	Connection Centers	Tube Quantity	Assembly Axis		Weight	Water Capacity	THERMAL POWER		
	W	H	D	C		S	L	kg.	lt.	btu	k/cal	watt
ECL050008800309	500	880	52	460	3	840	460	7,2	4,9	1632	411	478
ECL050013700609	500	1370	52	460	6	1330	460	11,1	7,9	2592	653	759

Vermogen (Watt) berekend op 75/65/20 graden Delta T50  
 Bij 90/70/20 graden vermenigvuldigd het vermogen met 1.26

# ECLIPSE



carisa<sup>®</sup>  
design radiator

The contents of this document are property of Termosan<sup>®</sup> and should not be copied, reproduced or disclosed to a third party without written consent of the proprietor.

www.carisa.com.tr

www.termosan.com  
info@termosan.com

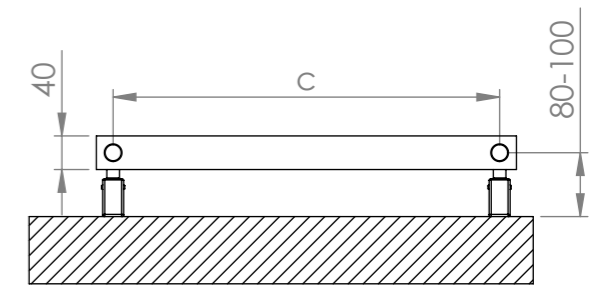
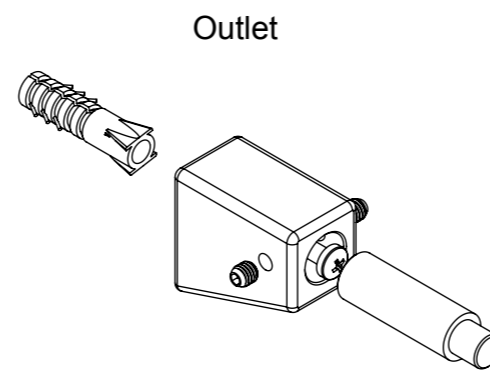
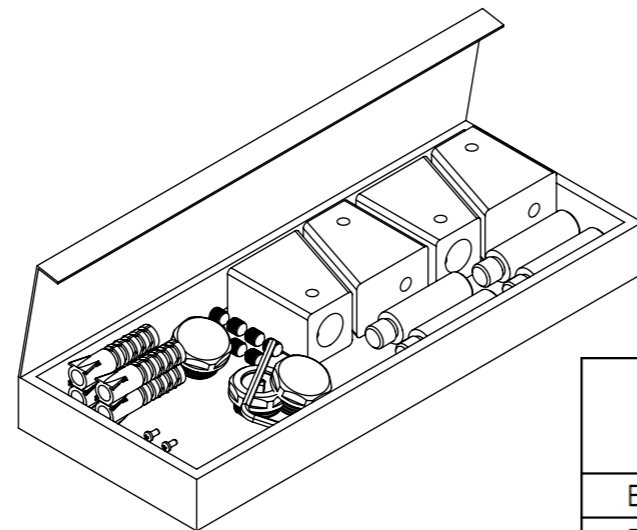
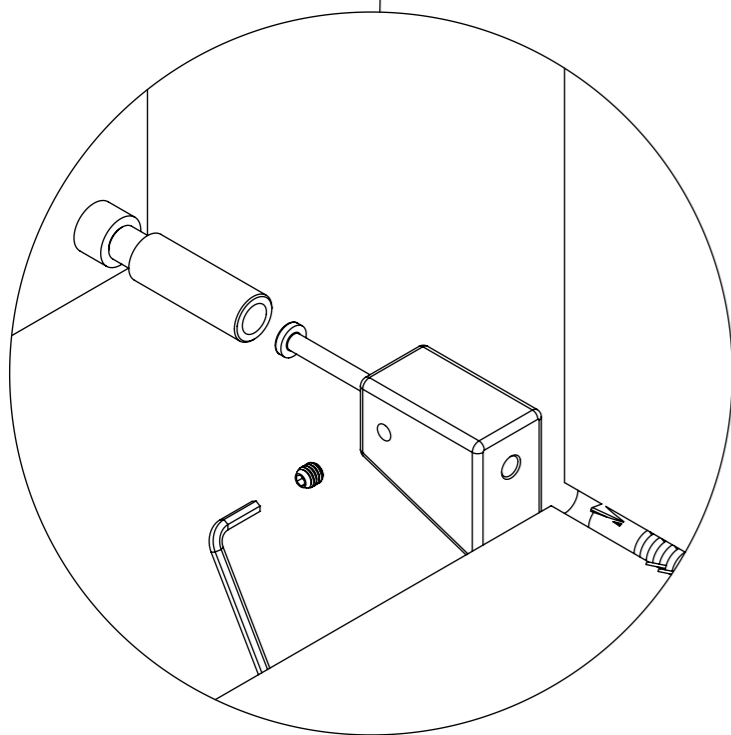
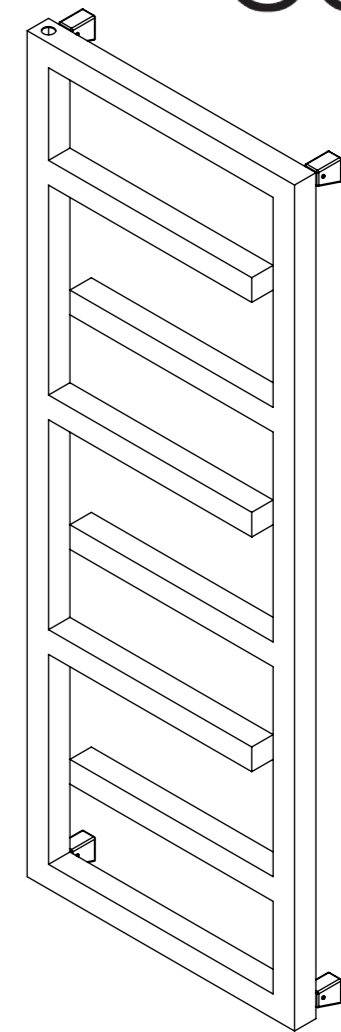
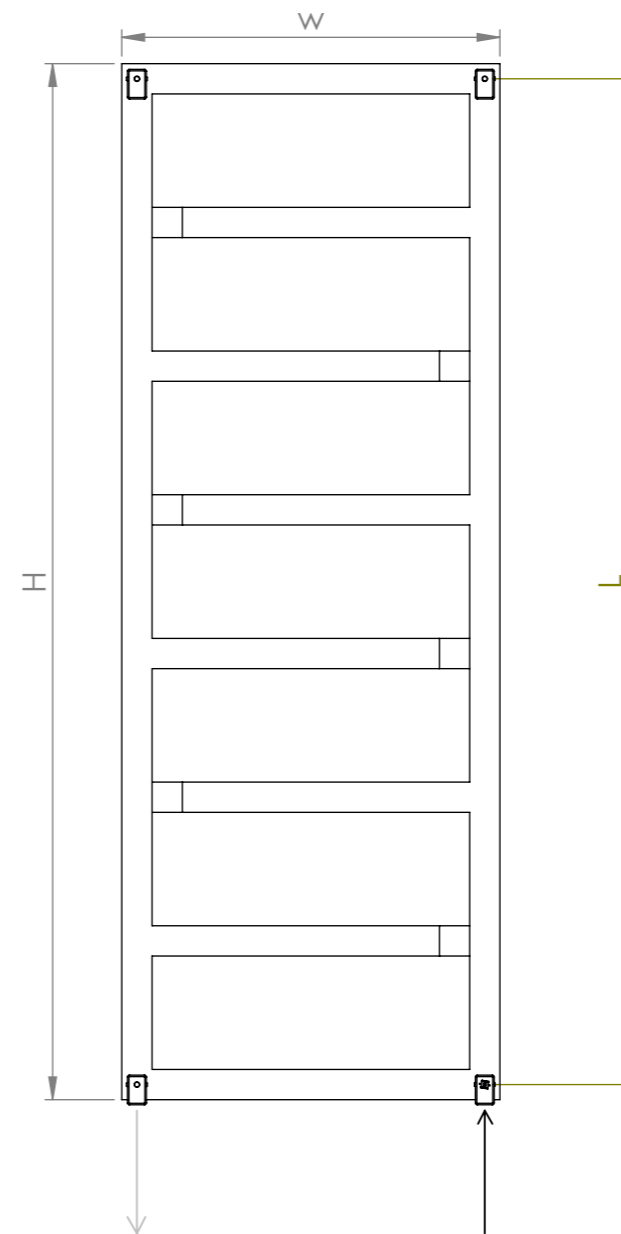
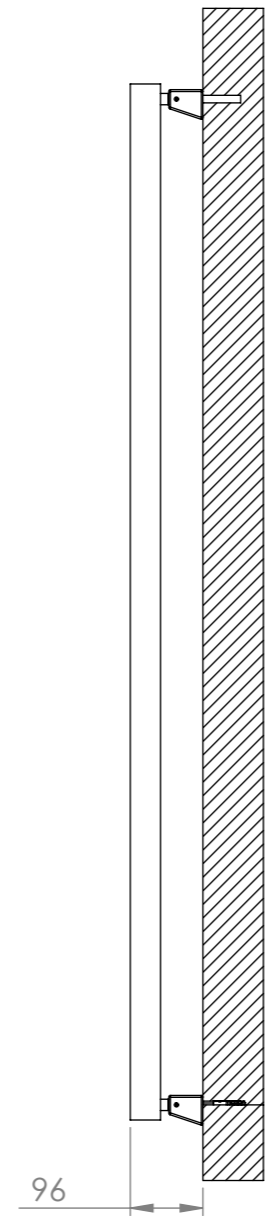
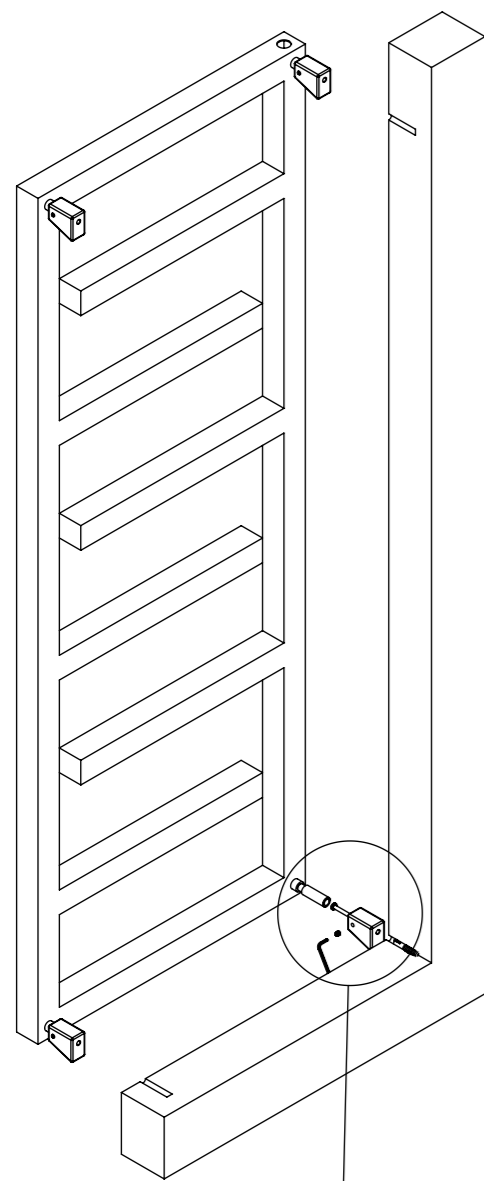

Bottom View

Product Code	Width	Height	Depth	Connection Centers	Tube Quantity	Assembly Axis		Weight kg.	Water Capacity lt.
	W	H	D	C		S	L		
ECL050013700609	500	1370	50	460	6	1330	460	11,1	7,9
ECL050008800309	500	880	50	460	3	840	460	7,2	4,9
ERO050013701209	500	1370	130	460	12	1330	460	22,2	15,8
ERO050008800609	500	880	130	460	6	840	460	14,4	9,9