

pan

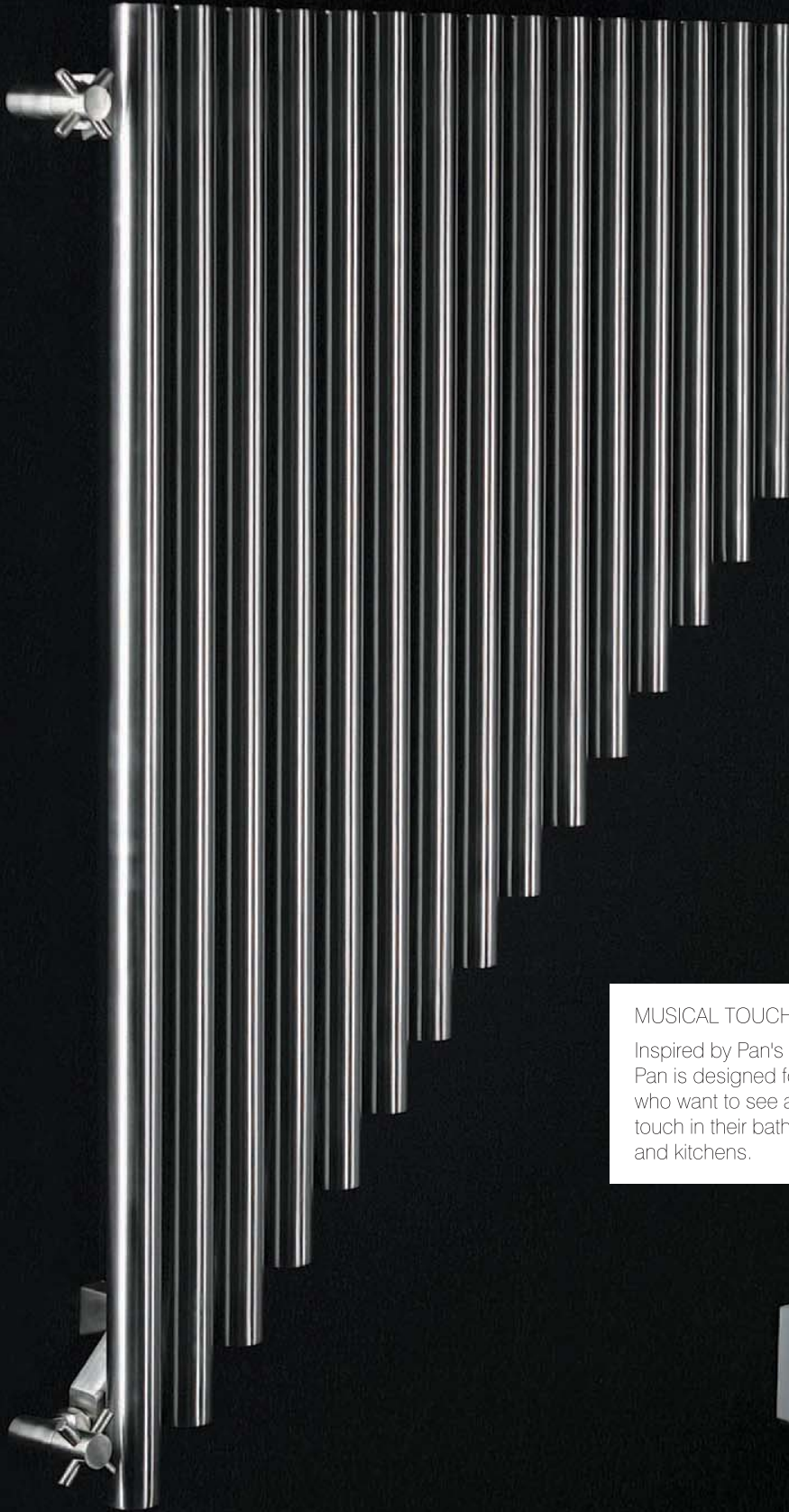

MUSICAL TOUCH

Inspired by Pan's flute, Pan is designed for those who want to see a musical touch in their bathrooms and kitchens.



technical specs page 133

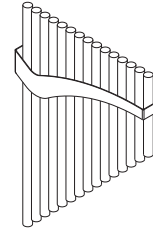
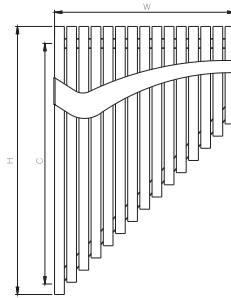
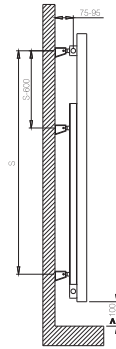
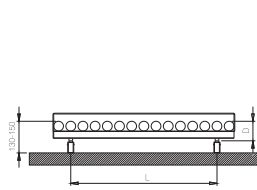

pan

material	finish	electric version	wall installation	warranty
stainless steel	satin polished	900 W	horizontal	10 years

max. working pressure: 10 bar
 max. working temperature: 95°C
 all dimensions are in mm.
 connections 1/2"

Product Code	Width	Height	Depth	Connection Centers	Tube Quantity	Assembly Axis		Weight	Water Capacity	THERMAL POWER		
	W	H	D	C		S	L	kg.	lt.	btu	k/cal	watt
PAF074011001509	740	1100	80	985	15	920	600	19,7	15,2	3692	930	1082

Vermogen (Watt) berekend op 75/65/20 graden Delta T50
 Bij 90/70/20 graden vermenigvuldig het vermogen met 1.26

PAN

The contents of this document are property of Termosan® and should not be copied, reproduced or disclosed to a third party without written consent of the proprietor.

www.carisa.com.tr

www.termosan.com
info@termosan.com

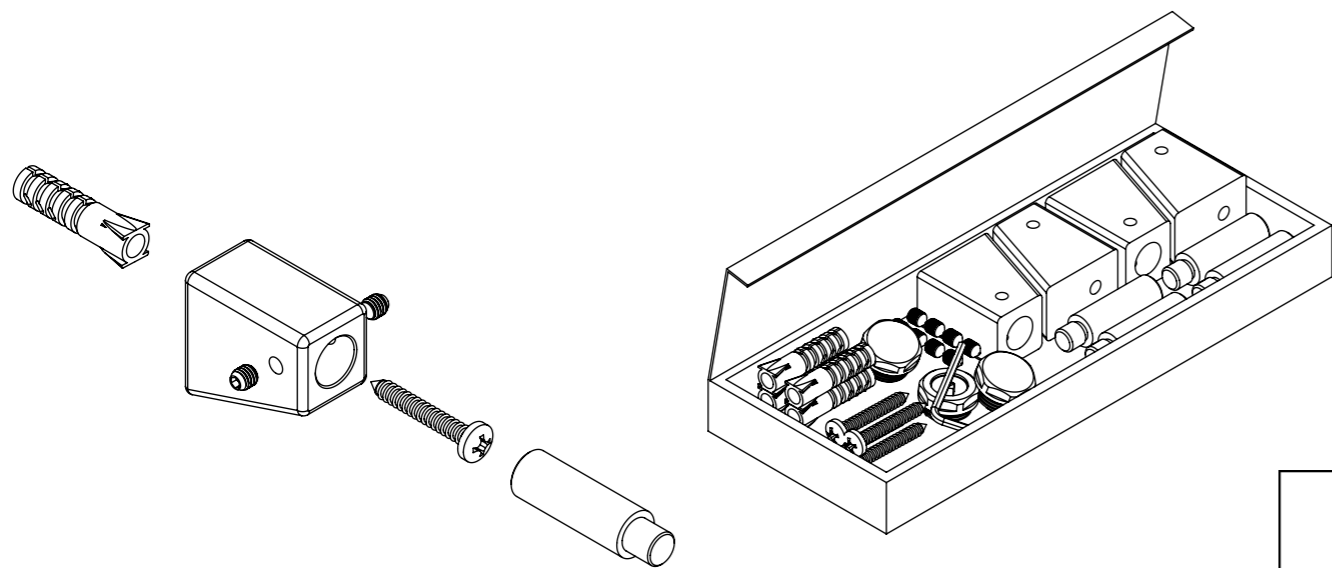
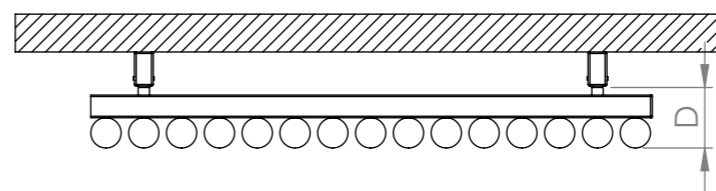
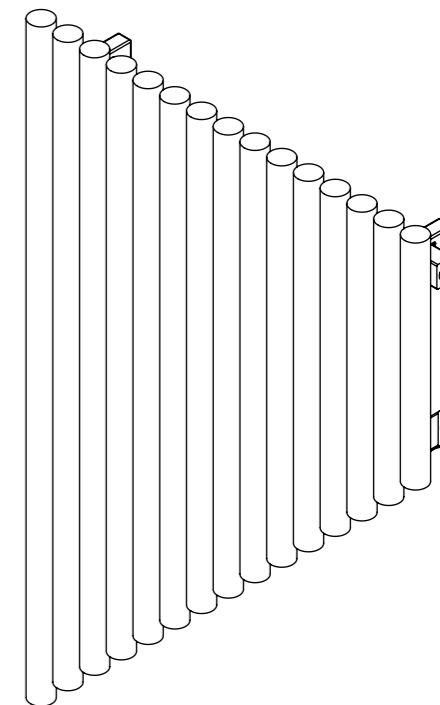
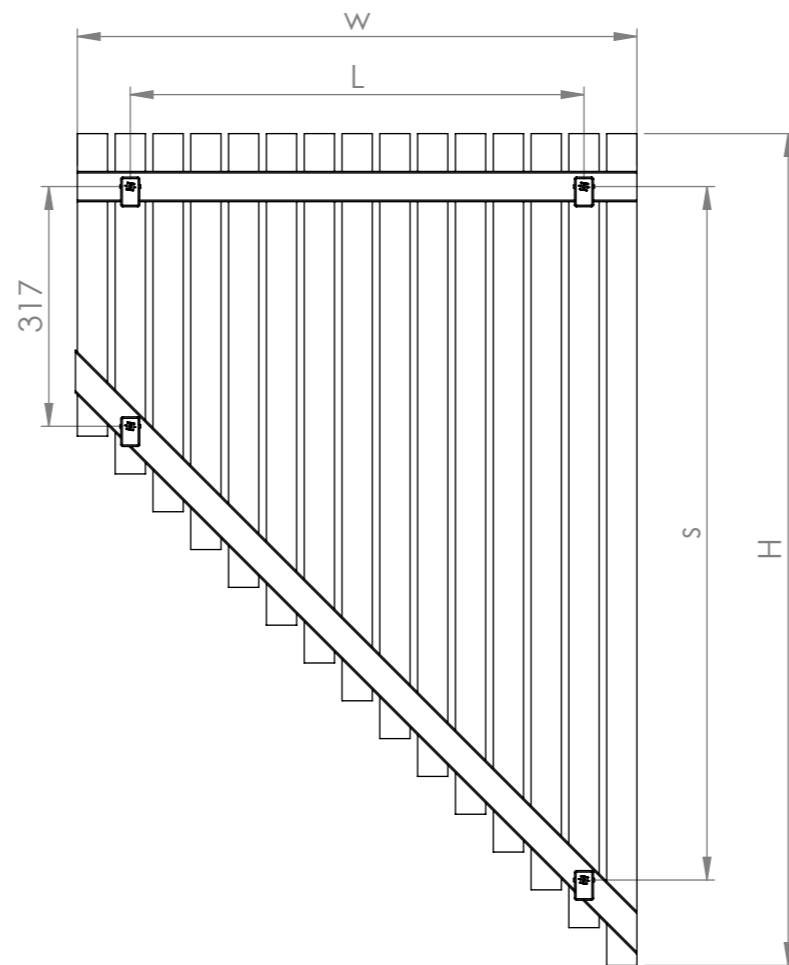
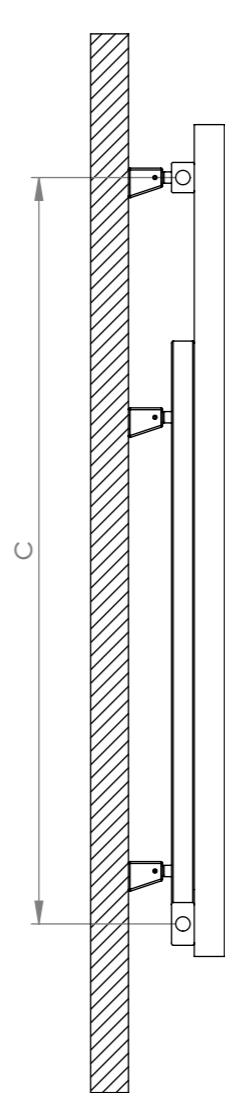
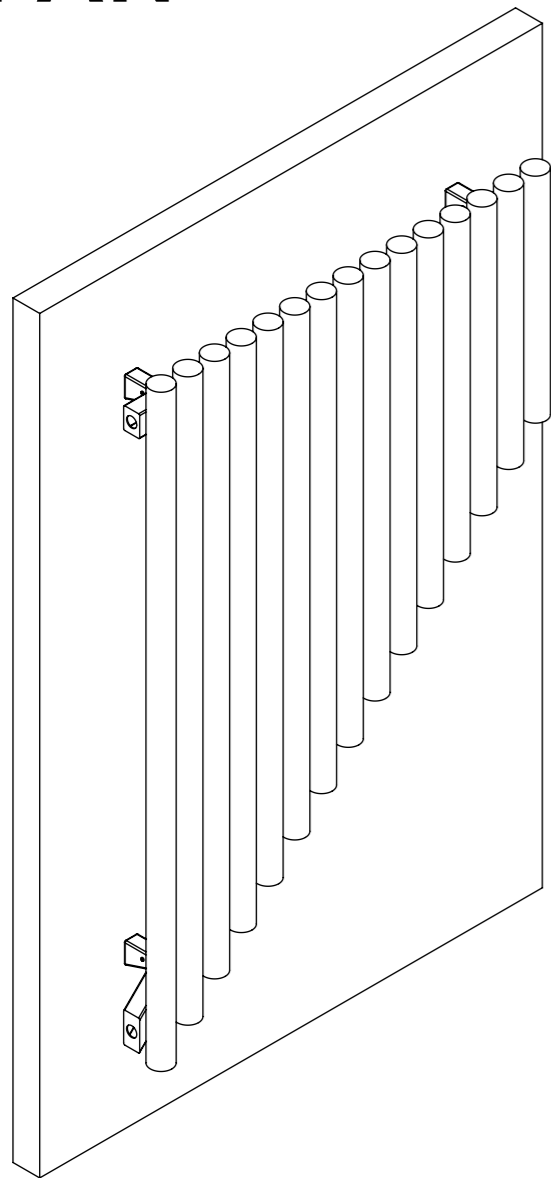

carisa[®]
design radiator

Product Code	Width	Height	Depth	Connection Centers	Tube Quantity	Assembly Axis		Weight	Water Capacity
	W	H	D	C		S	L	kg.	lt.
PAF074011001509	740	1100	80	985	15	920	600	19,7	15,2