

rushmore



PASSION OF STRENGTH

The classic design of Rushmore makes it simultaneously functional and commanding. The radiator of timeless strength.



technical specs page 111

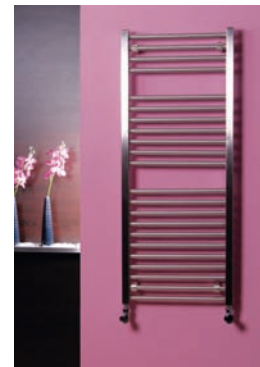
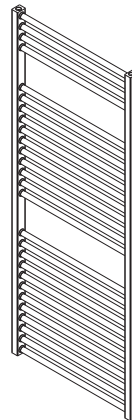
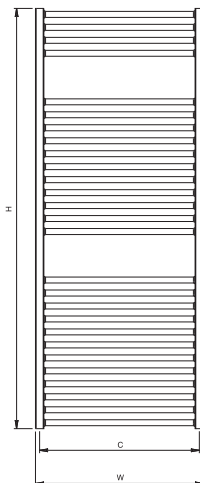
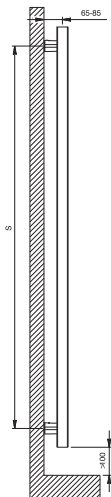
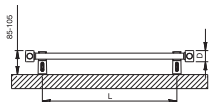

rushmore

material	finish	electric version	wall installation	warranty
stainless steel	satın polished	300 W 600 W 900 W 1200 W	vertical	10 years

max. working pressure: 10 bar
 max. working temperature: 95°C
 all dimensions are in mm.
 connections 1/2"

Product Code	Width	Height	Depth	Connection Centers	Tube Quantity	Assembly Axis		Weight	Water Capacity	THERMAL POWER		
	W	H	D	C		S	L	kg.	lt.	btu	k/cal	watt
RUS045007501409	450	750	40	420	14	602	330	6,6	2,8	1621	409	475
RUS045012002209	450	1200	40	420	22	1065	330	10,4	4,5	2563	646	751
RUS045015002709	450	1500	40	420	27	1296	330	12,8	5,6	3167	798	928
RUS060007501409	600	750	40	570	14	602	480	8,2	3,4	1962	495	575
RUS060012002209	600	1200	40	570	22	1065	480	12,8	5,3	3099	781	908
RUS060015002709	600	1500	40	570	27	1296	480	15,8	6,6	3826	964	1121

Vermogen (Watt) berekend op 75/65/20 graden Delta T50
 Bij 90/70/20 graden vermenigvuldig het vermogen met 1.26

RUSHMORE

The contents of this document are property of Termosan® and should not be copied, reproduced or disclosed to a third party without written consent of the proprietor.

www.carisa.com.tr

www.termosan.com
info@termosan.com

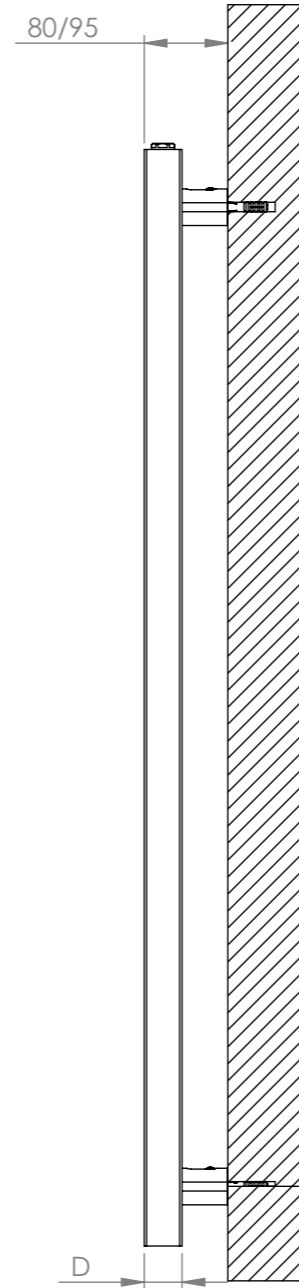
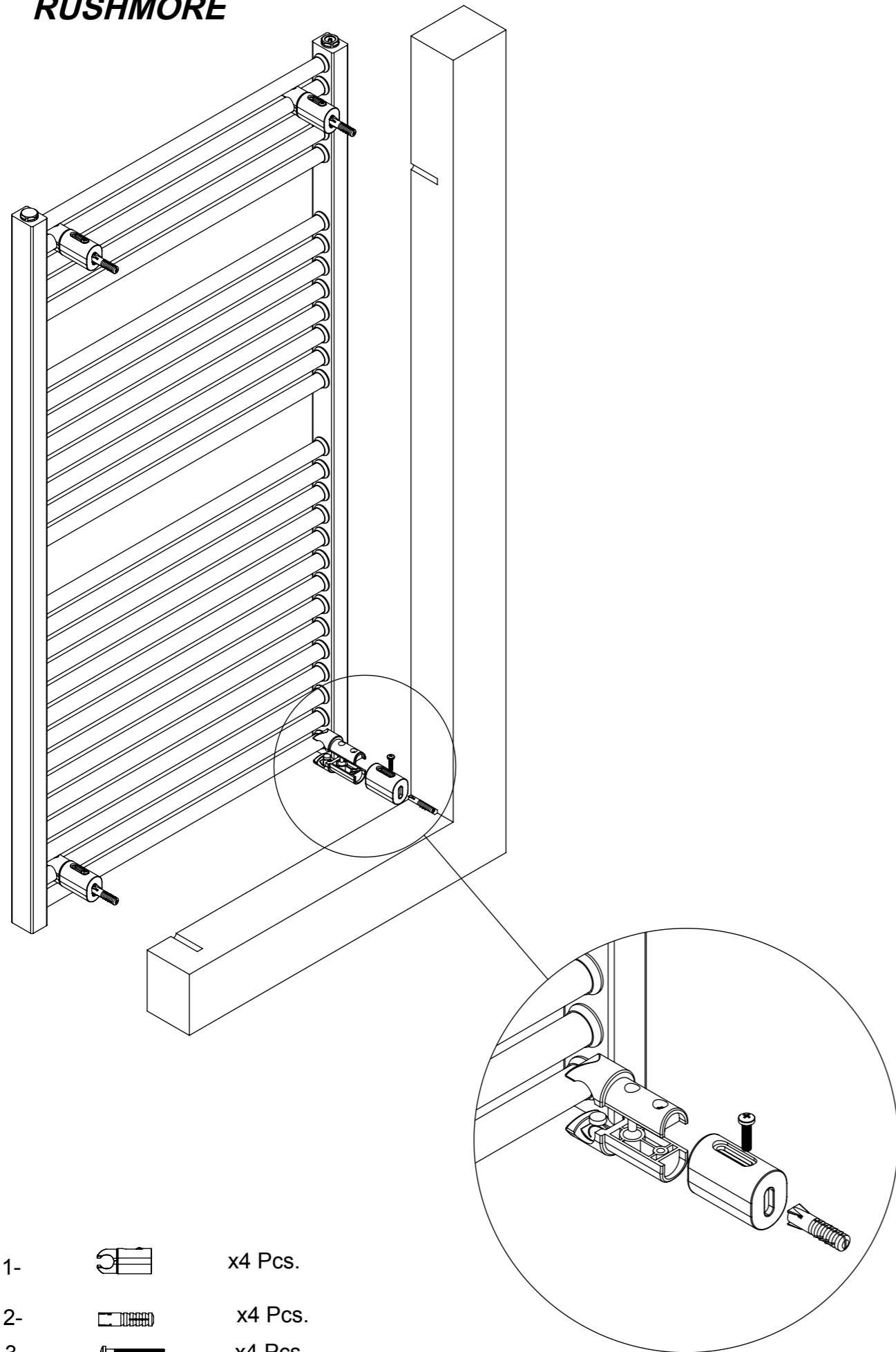



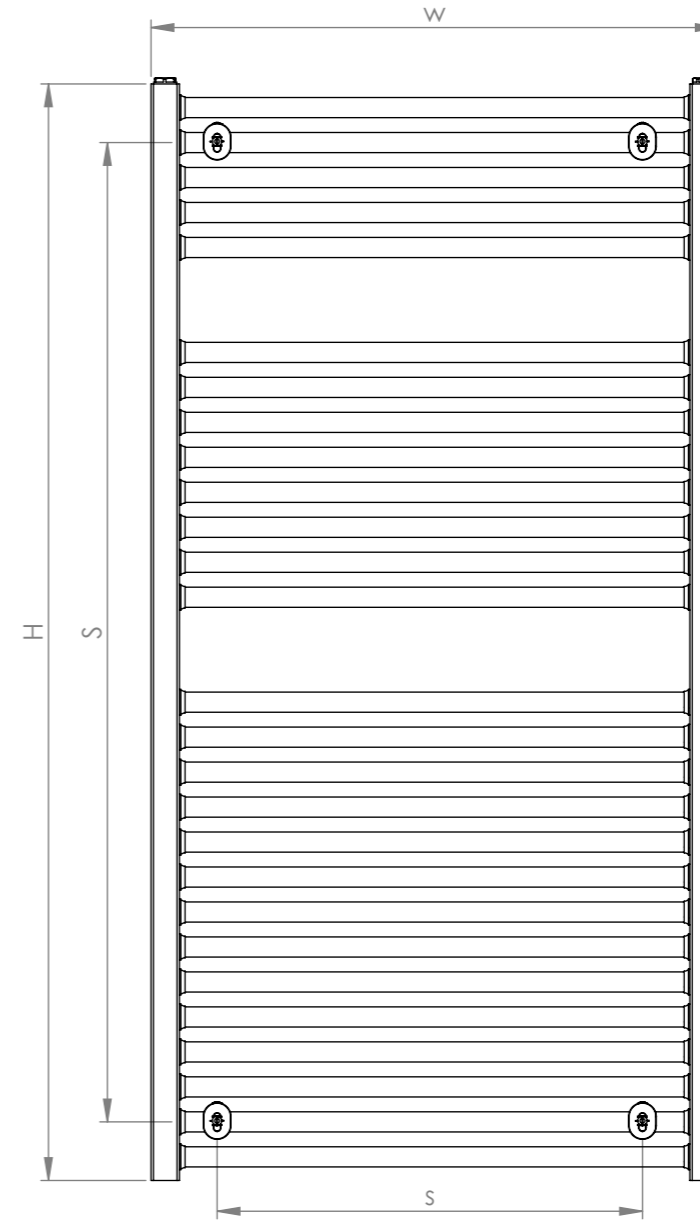

Side View

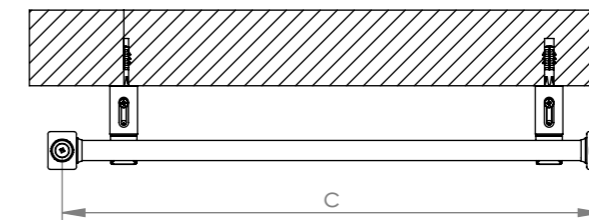

Assembly Axis



- 1-  x4 Pcs.
- 2-  x4 Pcs.
- 3-  x4 Pcs.
- 4-  x1 Pcs.
- 5-  x1 Pcs.

Product Code	Width	Height	Depth	Connection Centers	Tube Quantity	Assembly Axis		Weight	Water Capacity
	W	H	D	C		S	L	kg.	lt.
RUS045007501409	450	750	40	420	14	602	330	6,6	2,8
RUS045012002209	450	1200	40	420	22	1065	330	10,4	4,5
RUS045015002709	450	1500	40	420	27	1296	330	12,8	5,6
RUS060007501409	600	750	40	570	14	602	480	8,2	3,4
RUS060012002209	600	1200	40	570	22	1065	480	12,8	5,3
RUS060015002709	600	1500	40	570	27	1296	480	15,8	6,6